

Porsche, Andreas; Bernhardt, Gerd; Schute, Klaus; Mecking, Klaus

# Function investigations of a cooling system under high dirt load

A technical solution for avoidance and clearance of pollution (dirt, dust) at the cooling unit of a tractor is presented. The intake cooling airflow will be divided into a clean main airflow and a partial airflow loaded with dirt and dust. The partial air flow will be released into the environment before reaching the radiator of the cooling unit by placing a second additional fan in front of the radiator screen. A pivot-mounted cover plate, mounted in front of the second fan, rotates in cause of the air flow and creates turbulences, which allow the separation of dirt and dust.

## Keywords

Tractor, cooling unit, cooling air cleaning

## Abstract

Landtechnik 64 (2009), no. 3, pp. 194 - 197, 4 figures, 2 references

faster and safer road transport. Nowadays a whole battery of cooling systems can be found within the engine compartments of such tractors and these depend on high air throughput. Not least the increasing emission regulations demand ever-increasing cooling system performance for maintaining optimum operating temperatures of coolant, transmission and hydraulic oil, turbo air, fuel and, nowadays, exhaust gases.

This leads to large-dimensioned fans at appropriate speeds creating high air intake speeds at the front grill with associated high noise levels. Because of this, electronic speed-regulated fans are already being fitted. Also increased because of the rising intake air speeds and partly horizontal radiator grill surfaces is the danger of dirt blockages. When working in surrounds heavily laden with dirt the strong vacuum effect can completely block the grill which then has to be cleaned.

To reduce this downtime the air intake grill has to be dimensioned with a reserve that can tolerate a certain degree of dirt intake. Suppliers of air intake grills are faced with steadily growing challenges regarding design and perforated plate geometry. Small holes, minimum grill-member widths and honeycomb-form hexagonal perforations for maximum throughflow have become standard. For high stiffness along with a larger surface, perforated plates are radically reshaped and partly feature trapezoid folds.

## Objectives

The aim of these investigations was to find a new solution for design of the radiator air intake area so that in addition to separation and disposal of dirt and dust, an as far as possible continuous cleaning of the screen surface area could also be integrated as a function. The main aims involved were defined as:

■ Modern tractors have high engine performance enabling application of large-scale implements on the field as well as

Fig. 1

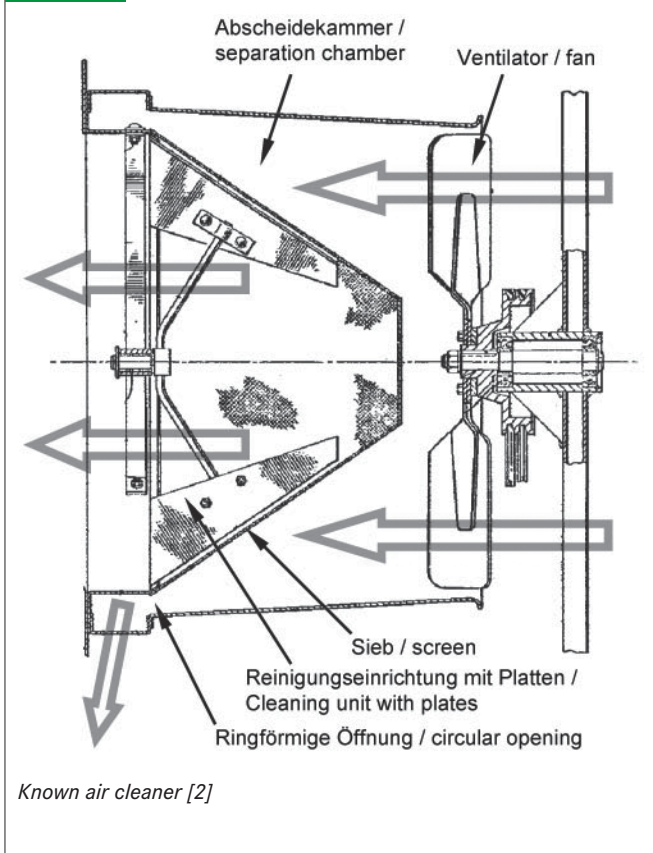

- Increased air throughflow at radiator without further enlargement of intake surface area.
- Continuous avoidance and removal of dirt particles at the radiator.
- Reliable dirt separation action, even with high dirt contamination of surrounding atmosphere.
- Minimum technical input with limited extra bonnet length.
- No increase in noise with higher cooling system performance.
- Avoidance of increase in power requirements.

### Ways towards a solution

A painstaking patent research involving the closer inspection of over 70 patent specifications formed the basis of this work. Particularly in combine harvester technology, where surrounding conditions in the field can be bad, very many solutions are known and have been already realised in practice. Tractors, too, are featured in a series of such solutions, although few have been applied in practice.

The ground element for cleaning the cooling airflow is usually a fine-perforated screen keeping dirt particles away from the radiator whereby liable to dirt blockage itself. There are different solutions for cleaning such a screen. Simple technical solutions partially interrupt the airflow. More complex answers employ additional aids such as fixed or rotating brushes, partial or complete reversal of airflow, partial vacuuming action from outside,

Fig. 2

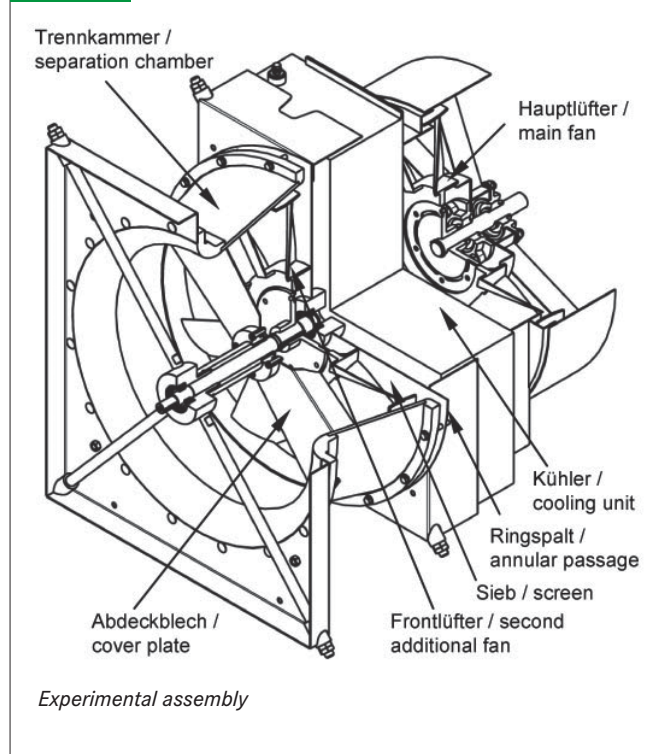

application of compressed air onto the outer screen surface and also rotating or endless belt screen surfaces. Often such aids are combined with one another.

Other systems also known divide the cooling air flow into a partial stream carrying dirt and a main stream of cleaned air (figure 1) whereby the partial stream pulls dirt particles lodged on the screen outer surface free and carries them back into the atmosphere.

From a series of different solution ideas the experimental assembly illustrated in figure 2 was favoured. This features a separation chamber mounted in front of a standard combination of radiator with main fan behind. The cooling combination and the separation chamber are completely separated from one another by a perforated screen with flat or slightly conical form. A second so-called front fan is positioned within the separation chamber near the screen. A separate bearing-mounted rotating cover plate is fitted very near the front fan. Together, separation chamber and screen form an annular passage through which the partial air stream carrying the dirt particles escapes.

### Investigations

To prove its functional efficiency the experimental assembly illustrated in figure 2 had a mixture of chaff and short straw conveyed towards it via conveyor belt. As expected, the air stream from the main fan alone drew a large proportion of the dirt particles onto the screen surface. Within the shortest time the screen surface was completely covered in dirt.

With subsequent activation of the front fan the air stream onto the screen surface was strengthened. The pressure increase in front of the screen led to the creation of a partial air stream

directed through the annular gap which first flowed over the screen surface and pulled dirt particles adhering there out of the cooling area. Tested were conical or flat screens as well as different versions of front fans. The fan speed, annular gap width and air flow direction at the annular gap were all varied.

**Results**

**Function.** An important discovery of these function tests is the importance of the positioning of a second fan. The first, so-called main fan creates a main air stream which flows through the radiator. The second so-called front fan creates an additional partial air stream that is to the greatest extent independent from the main air stream and that flows out through the annular gap. This front fan works most effectively when it is positioned a minimum distance from the screen surface. The dirt separation can be increased further when a cover plate is positioned in front of the front fan. This sort of cover plate creates air turbulence in its lee which detaches clinging dirt particles. A rotating cover plate with attached air-directional fins has the effect of causing a continually repeated partial covering of the screen surface with rapid cleaning effect on the entire screen surface. This enabled further tests to move over to a flat form of screen surface from the initial conical form.

**Air throughflow.** The airflow through the radiator was measured indirectly via the air speed behind the radiator. The separate drives of main and front fans (identical models) were, with comparable rpm, very different regarding air throughflow through the radiator and this was true also when the annular gap was completely closed (figure 3). This was caused by the very different airflow directions. The combined use of main and front fans could increase throughflow through the radiator by

up to 30% through the general pressure increase in front of the screen, or it could maintain the throughflow while reducing the speed of the main fan by up to 25%.

**Power requirement.** Power requirement was determined through measurement of torque and rpm in each case separately for front and main fan working alone as well as combined operation of both fans with 29 speeds tested. At first it could be established that the both fans with regard to power requirement and rpm influenced one another minimally. For this reason in figure 4 all values of the main fan with six different front fan speeds and all values of the front fan with five different main fan speeds are drawn together in one performance curve.

In the tests presented, the main fan required 3.9 kW power with one screen and speed of 2100 rpm. The performance curve of the same-model front fan is steeper in comparison with that of the main fan.

With activation of the front fan and a speed of, e.g., 1040 rpm the speed of the main fan can be reduced from 2100 to 1825 rpm (P1 in figure 3) without a reduction in airflow speed. Under normal conditions the fan can be driven in the lower performance line area, for instance at the work rate signified by P1, thus making a reduction in power requirement of 15% possible. However, the cleaning action first begins with a minimum front fan speed of 1650 rpm whereby the main fan speed can be reduced to 1600 rpm without air throughflow reduction. Hereby the total power requirement increases with full cleaning effect and unaltered high cooling effect only minimally at 8%. Over a short period both fans can be accelerated to their full permitted speed in order to give an above-average cooling performance by full cleaning effect. Hereby, however, total power requirement rises by over 150%

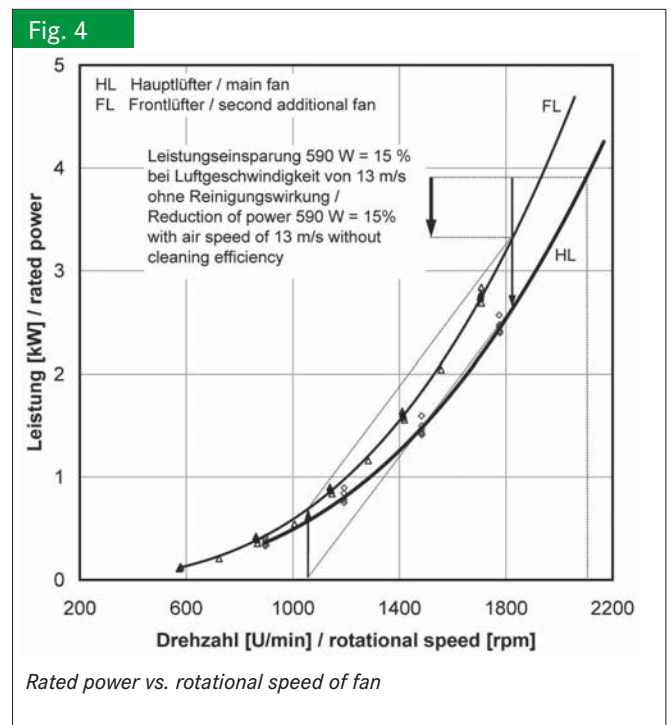
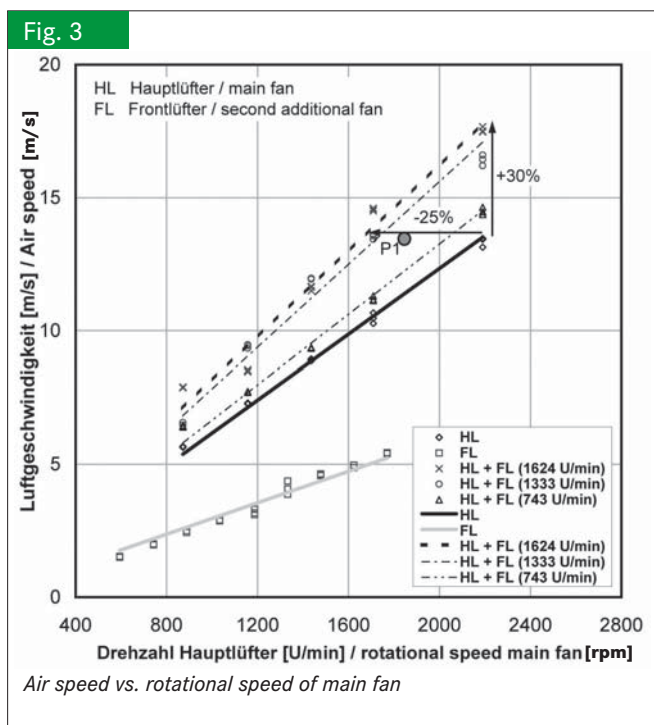

**Noise level.** The noise level depends on fan speed. With a main fan speed of 2100 rpm the noise level in the research facility was measured at 86 dBA which did not rise further even when in combination with the front fan running at 1600 rpm. With simultaneous use of both fans with speed reduced to around 1600 rpm a reduced noise level of 82 dBA was indicated.

**Control strategies.** A large number of control strategies can be derived, especially based on coolant temperature but also for reducing the total power requirement and the noise level. A simple control can take place via the coolant temperature whereby both fans initially work in the lower speed area. In order to avoid dirt contamination with increasing coolant temperature the speed of the front fan can at first, e.g., be increased by a minimum value and only then, when required, the main fan speed further increased. Further management factors, such as torque on the fan shaft, can give an early warning of dirt contamination without the coolant temperature first becoming critically high.

## Literature

- [1] Bernhardt, G.; Porsche, A.; Mecking, K.; Schute, K.: Ein effektives Kühl-ersystem für Traktoren und Erntemaschinen bei hoher Staubbelastung. Tagungsband VDI-MEG-Tagung Landtechnik, Stuttgart-Hohenheim, 2008
- [2] Patentschrift DE 2363190

## Authors

**Dipl.-Ing. Andreas Porsche** is a member of the scientific staff at the Lehrstuhl Agrarsystemtechnik (Director: **Prof. Dr.-Ing. habil. Herlitzius**; Ex-director: **Prof. Dr.-Ing. habil. Bernhardt**) at the Institut für Verarbeitungsmaschinen und Mobile Arbeitsmaschinen, Technical University Dresden, 01062 Dresden, e-mail: porsche@ast.mw.tu-dresden.de

**Dipl.-Ing. Klaus Schute** is construction manager with Friedrich Graepel AG (Chairman: **Klaus Mecking**), 49624 Lönningen, e-mail: schute@graepel.de