

Anisch, Siegfried

Retrospect: studies on the development of ploughs with a low overall length – short-ploughs

Basic and applied research for mechanical tillage were operated at the Dresden University of Technology from the 1960s to the 1980s. This happened in coordination with the Academy of Agricultural Sciences of the GDR and the agricultural machinery industry. This paper describes the investigations on the Department Construction of Agricultural Machinery (now: Chair of Agricultural Systems and Technology) to 1978, carried out to reduce the staggering distance of plough bodies. Based on theoretical studies, experiments in the soil bin and in field were conducted. The work was finished with the field test of a 12-furrow-short-plough with a working width of 6.0 meters by a length of only about 3.5 meters.

Keywords

Short-plough, mouldboard, soil-bin, field test

Abstract

Landtechnik 65 (2010), no. 4, pp. 293-297, 7 figures, 11 references

■ Share ploughs were the characteristic implement for seed bed preparation in the years from 1960 through 1980, because they fulfilled best the phytopathological requirements to completely remove plant residue from the upper soil layer. The growing amount of small grain farming created higher volumes of straw, weeds or even dung, which were best incorporated into the soil by turning it under using ploughs [1; 2].

Conventional ploughs employ a staggered arrangement of single bodies that allows enough inter-body clearance in order to ensure field operation without plugging. Plough design for powerful tractors is usually 2.5 to 3 times longer than wide. At wider working width and uneven terrain it can become a problem to maintain consistent working depth. Articulated frames and comprehensive undercarriage concepts help to address this problem, which makes these conventional ploughs incapable to work in combination with seed bed preparation tools or seeding implements and therefore creating a limitation in productivity.

The requirements for the combination of ploughs with sequential tasks drove the development of new concepts of plough body arrangements that deliver no (cross plough) or very little (short plough) staggering depth [3].

Theoretical analysis of plough bodies for short ploughs

Conventional share ploughs continuously cut a soil bar with rectangular cross section and turn it into the open furrow that was created by the leading plough body. Rectangular soil sections at one level have to be turned in sequence in order to ensure a continuous and reliable work process. By modifying the cross section the distance of critical points of contact between two soil bars can be enlarged. Based on theory the parallelogram shape is the optimal cross section if plough bodies are put side by side (**figure 1**) [4].

The solution for short ploughs known from patent literature were evaluated as not relevant for practical applications [5]. A simulation model with the working principle „Cutting of soil with parallelogram shaped cross section and turning into the neighboring furrow“ was developed to determine the design parameters of the 3-dimensional mouldboard surface. Main design parameters were (**figure 2**):

- cross section of the soil bar, determined by width (b), depth (t) and furrow angle (α)
- execution of the cutting edge for bottom and side wall of the furrow
- characteristic of the turning angle (φ) with a progressive growth against the direction of travel (x)

It was, however, not possible to either select design parameters for an optimization or to define a mathematical target function which would consider the following aspects:

- maximized distance between soil bars to allow a working process free of plugging

- deviation between theoretical and real behavior of the soil bar
- influence of organic residue
- result of the ploughing process
- power requirements for draw power

The mouldboard was designed by turning a characteristic curve within the front side projection plane and moving it along the horizontal projection plane. Room for supporting elements (frog, leg) exists close to the area where the turning angle is $(\varphi) = 90^\circ - (\alpha)$ [6]. The analytical research defined the main characteristics of a mouldboard of a plough body that can be arranged within a small staggering depth:

- helical shape with a progressive growing turning angle (φ)
- vertical cross sections of the cut soil strip, which have an approximated parallelogram shape
- cross sections of the soil strip with a width to depth ratio $k = b/t > 1.8$ and an angle of the side wall of the furrow $(\alpha) = 50-70^\circ$

For the development of the plough body and the short plough concept the following issues were crucial:

- Due to the small staggering depth lateral forces could not be supported from the furrow side wall since the next body is following and does not allow for the space to use a conventional landside board. Forces had to be transferred through the plough frame to the last body, which is

able to be supported from the furrows side wall.

- The supporting structure of the plough bodies had to be placed away from the area where the soil strip is moving in order to avoid gathering and accumulation of soil and organic material.
- Soil cutting tools (preferably coulter disks) had to be placed in front of each share to safely cut plant residue at the surface, which is important to avoid plugging.
- In case of a rigid support of the soil cutting tools they can be utilized to transfer lateral forces from the plough bodies, which can save about 30 % of traction-force due to the lower friction [7].

Fig. 1

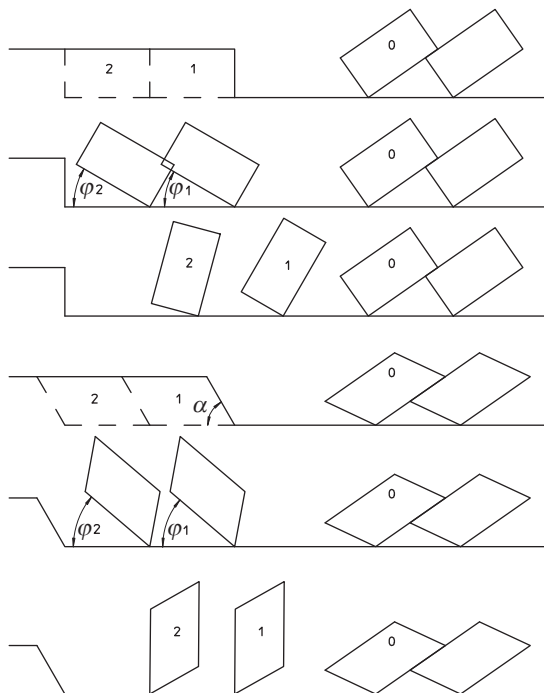

Turning process with rectangular and parallelogram soil cross-sections (schematic)

Fig. 2

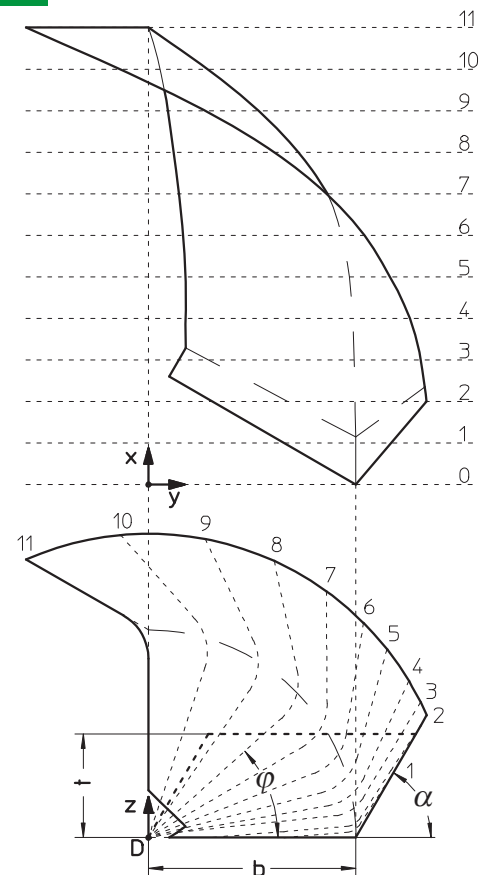

Construction scheme of the helical mouldboard for an parallelogram soil cross-section [5; 6]

Experimental research in the soil bin and the field

Experimental research in the soil bin and field were conducted to gather knowledge about:

- effect of staggering depth and turning angle on the resulting plough body forces
- deviation between expected and real cross section and distance of the adjacent soil bars
- functional reliability of the plough bodies
- capability to meet the agro-technical requirements

Three different sets of plough bodies were manufactured for the test runs (**figure 3**).

Forces and distances between soil bars were measured in the field at the middle share of a special three body test rig and a two body measuring frame in the soil bin (**figure 4**). Results for a multiple share plough were showing that the forces in longitudinal (f_x), cross (f_y) and vertical (f_z) direction were growing below a certain limit of staggering depth (**figure 5**).

Slow motion video and single frame evaluation were delivering the following results regarding the movement of the soil bars:

- The turning process happens in the soil bin and the field (stubble, loamy sand and loamy silt, green vegetation, soil density 1.4 g/cm^3 , soil moisture 16 %) according to the theoretical model. The parallelogram shape of the soil bar remains mainly the same while moving over share and mouldboard.
- The little deviation between the theoretical and real trajectories of the soil allowed a side by side arrangement ($S = 0$) in a way that the remaining space between the edge of the furrow and the next plough body could be utilized to support share and mouldboard against the frame using a narrow design of frog and leg.

Based on these findings experimental ploughs (**figure 6 and 7**) with four and six plough bodies and additional tools to mix in organic material were tested on several locations. The results can be summarized as follows:

- Function of a short plough is reliable as long as the cut soil bar is maintaining its shape while moving over share and mouldboard. Lighter soils with less cohesion and higher friction against the mouldboard are problematic due to the inherent risk of filling up the free space between adjacent plough bodies, which eventually leads to plugging. The same risk exists for fields that have been cultivated or disk mulched before ploughing.
- By placing a disc couler in front of the cutting edge for the furrow wall of each bottom are clogging avoided, even with strong growth and high crop residues. On the existing field surface organic substances are located in strip. The complete accommodate possible through the use of baffles.
- Topsoil short ploughs usually do not have to deal with mulch layers in the field and therefore can fulfill there function at almost all soil types. Due to the compact size

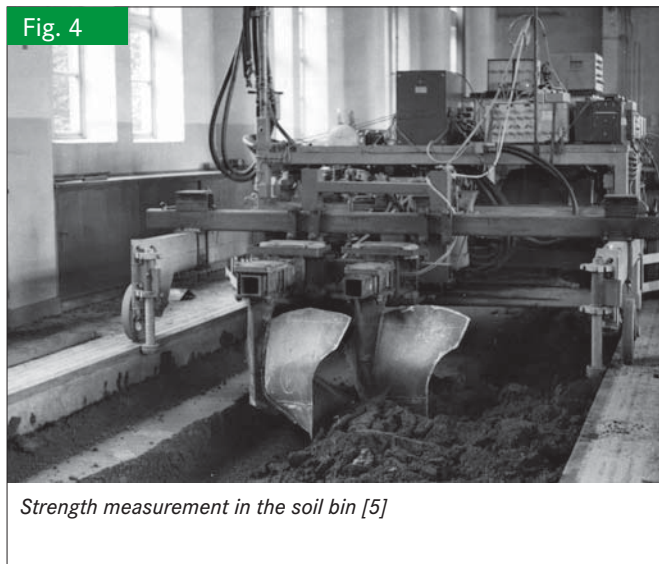
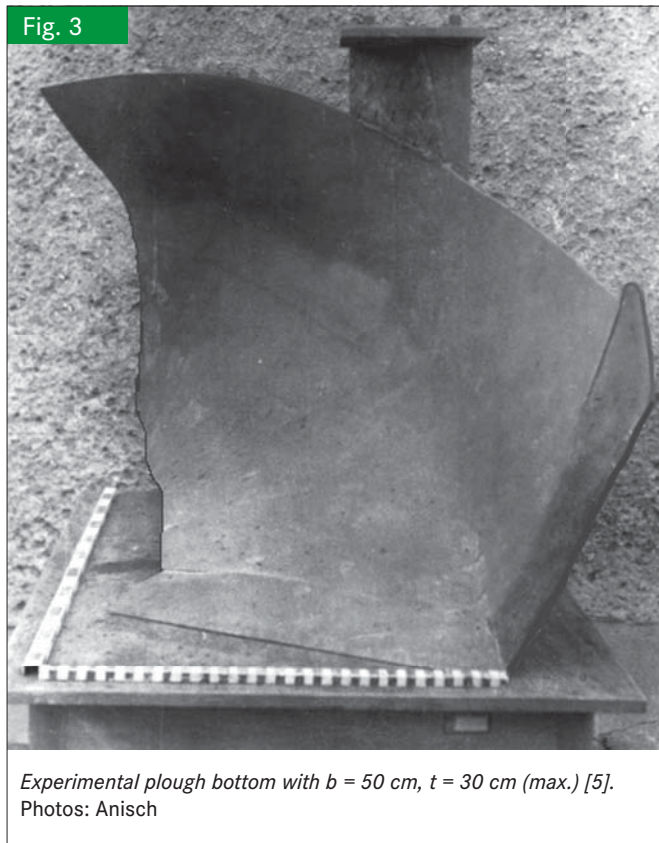

and the advantageous length to width ratio the center of gravity is closer to the tractors rear axle, which allows even wide ploughs to be connected to the tractor at the three point linkage (**figure 7**) [8].

- The research on short ploughs were discontinued since the design was still not short enough, the specific traction force requirements remained unchanged high, the functional reliability on light soils showed limitations and the requirement of changing the process chain of tillage and seeding of small grain.

Fig. 5

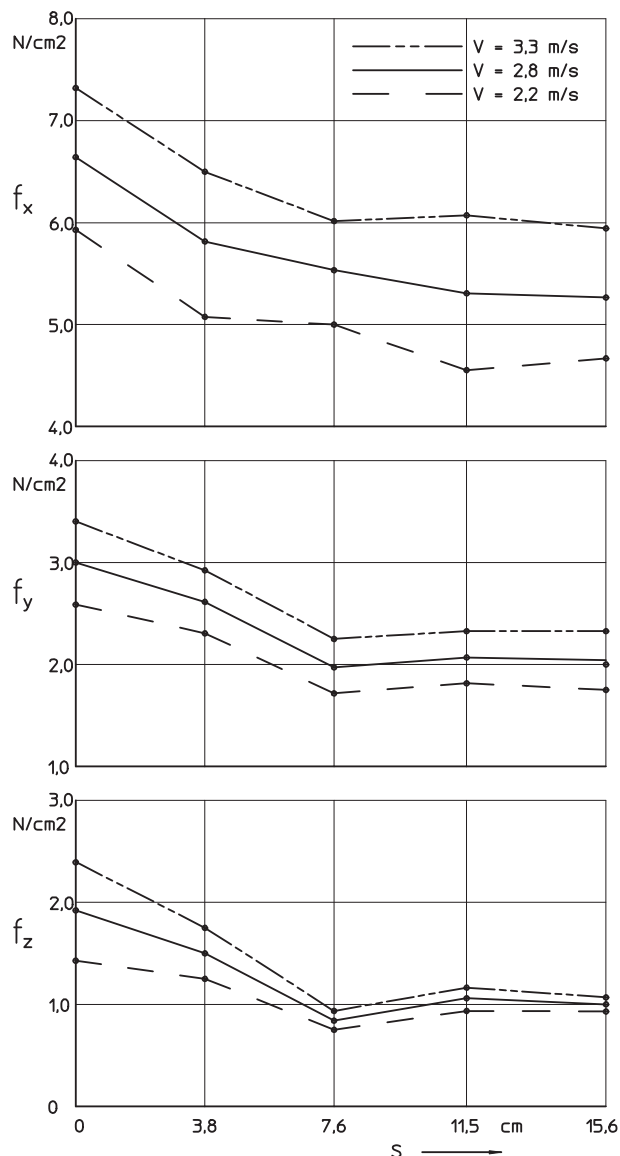

Specific forces f_x , f_y , f_z at the middle of 3 plow bottoms depending on the staggering distance S at different speeds v in the field [5]

Plough technology today

The plough is staying an important tool in tillage processes even though plough less and low till seed bed preparation have decreased cost in biomass production. The inter-body distances of plough bodies could not be reduced towards short plough concepts. They are 85-120 cm along the plough frame (which results in a staggering depth of $S = 73-97$ cm) [9; 10].

Especially with three point mounted reversible ploughs with up to seven plough bodies the rear axle of the tractor becomes overloaded when turning on the headland creating recognizable soil compaction with the result of decreased soil fertility. Ploughs that create an angled furrow wall („Rautenpflug“, com-

Fig. 6



Short-plough (working width $B = 2,0$ m; staggering distance $S = 18$ cm)

Fig. 7



Experimental-plough with frame joints (working width $B = 6$ m; staggering distance $S = 13,5$ cm) [5]

pany Gassner, Huard) to allow to ride in the furrow even with wider tractor tires cannot be found on the market anymore. Today plough development for productivity increases is focusing on:

- assisting and automation of connecting the plough to the tractor, adjustment of working width, working depth and resulting traction force vector as well as stone protection or headland management
- reducing of wear (increase of life time) of all plough body parts [11].

Literature

- [1] Kunze, A.: Bodenbearbeitung und Bestellung in hoher Qualität – eine wichtige Voraussetzung für die Steigerung und Stabilisierung der Erträge. Agrartechnik 24 (1974) H. 1, S. 20–22
- [2] Feuerlein, W.: Pflügen – oder was sonst? Landtechnik 28 (1973) H. 15, S. 401–404
- [3] Kunze, A.: Komplexe Aufgabenstellung für Verfahren und Technik der kombinierten Bodenbearbeitung und Bestellung entsprechend den Erfordernissen der industriemäßigen Produktion. Akademie der Landwirtschaftswissenschaften, Forschungszentrum für Bodenfruchtbarkeit, Münchenberg 1974 (unveröffentlicht)
- [4] Anisch, S. und R. Richter: Zum Arbeitsprinzip eines Kurzpfluges auf der Grundlage des Wendens von Bodenbalken mit parallelogrammförmigem Querschnitt. Agrartechnik 27 (1977) H. 7, S. 323–325
- [5] Anisch, S. und R. Richter: Untersuchungen zur Gestaltung der Arbeits-

fläche und zur möglichen Staffelung von Pflugkörpern – ein Beitrag zur Entwicklung von Pflügen mit geringer Baulänge. Dissertation. Technische Universität Dresden, Fakultät Maschinenwesen, 1979

- [6] Anisch, S. et al.: Pflugkörper. Patentschrift DD 122768 A1
- [7] Anisch, S.: Abstützung der Seitenkräfte durch passiv rollende Scheiben. Agrartechnik 30 (1980) H. 9, S. 419–420
- [8] Anisch, S. et al.: Scharpflug für große Arbeitsbreiten. Patentschrift DD 134033 A1
- [9] Pflügen. www.lemken.com. Zugriff am 15.03.2010
- [10] Pflüge. www.poettinger.at. Zugriff am 15.03.2010
- [11] Herlitzius, T. und A. Grosa : Bodenbearbeitungstechnik. In: Jahrbuch Agrartechnik 21, DLG-Verlag, Frankfurt/Main, 2009, S. 87–94

Author

Dr.-Ing. Siegfried Anisch, born 1939, studied 1958-1964 mechanical engineering (Dipl.-Ing.) and specialized in agricultural engineering at TH/TU Dresden. 1964-1971 he was Head of Research Department at Gelenkwellenwerk Stadtilm (Thuringia). Dr.-Ing. Anisch worked 1971-1991 as a Research Assistant Professor at Department Construction of Agricultural Machinery of Dresden University of Technology. 1979 he graduated at Faculty of Mechanical Engineering of TU Dresden. 1991-1998 he was Head of Design at Eberhardt Maschinenfabrik GmbH. 1999-2002 he was Head of Design at Eberhardt-Mengele productions GmbH and 2002-2004 at Bohnacker AG/Mengele Agrartechnik, Waldstetten (Bavaria), E-Mail: siegfried.anisch@tele2.de

Remarks

The pool of experience of past generations is not only delivering interesting details but can also provide valuable ideas for managing the future. Following this motto the section History of Agricultural Technology within the German Society of Agricultural Engineers (VDI-MEG, Fachausschuss Landtechnik) has the objective to dig out and publish historical facts of agriculture. Such topics can find their place in papers like Landtechnik, as for example here the article from Dr. Anisch. The section has the goal to acquire for this interesting task as many authors as possible out of the large community of competent agricultural engineers in West and East Germany. We hope for further suitable offers for publication from the readers of Landtechnik.

signed Dr. Klaus Krombholz,

head of section History of Agricultural Technology within VDI-MEG,
E-Mail: klaus.krombholz@t-online.de